



Radiar AR10

2 channel AC powered 0-10V
room controller with inbuilt relay



Product Overview

Radiar AR10 is a BLE5.2 controllable, dual-channel 0-10V room controller. The device is powered by 90-277VAC voltage, also has a 20A relay to use it as a room controller or as a plug-load controller. It comes with Class-1 and Class-2 dual channel 0-10V dimming outputs, 0-10V sensor input, and 12V auxiliary output. The high output ratings within the device makes it suitable to control multiple numbers of light fixtures within a room. The device comes with 150mm external wire antenna for communication.

The Lumos Controls ecosystem comprises controllers, sensors, switches, modules, drivers, gateways, and analytical dashboards, and can be connected to the Lumos Controls cloud for data analytics and configuration management. The lighting network's configuration, commissioning, and controlling can be done super-quick from any mobile device. The ecosystem is listed by the **Design Lights Consortium (DLC)**, qualifying it for energy conservation incentive programs and rebates utility companies in North America.

Specifications

Electrical

Specifications	Value	Remarks
Input voltage	90-277VAC	
Input current	40mA @230VAC	75mA @110VAC
Frequency	50-60Hz	
Load voltage	90-277VAC	
Load current	20A	General purpose
	20A	Tungsten
	20A	Standard ballast
	16A	Electronic ballast
	1.5HP	Motor
Max load output wattage	5kW	@277VAC
Inrush current	4A	
Surge protection	4kV	
Standby current	14mA @110VAC	12mA @230VAC

Features

- Class-1 and Class-2 dual channel 0-10V outputs to control the dimming and CCT
- Load control up to 20A @ 90/277VAC
- It acts as a Plug load controller to manage, control and monitor the plug loads efficiently
- UL924 listed options for simplified lighting control on emergency lighting circuits
- UL2043 listed for plenum applications
- Auxiliary 12V/100mA output to power the sensors
- 0-10VDC input channel to integrate with third party sensors
- Instantaneous current and voltage measurement of connected load ($\pm 1\%$ accuracy)
- BLE5.2 based non-flooding intelligent communication
- Standard ½ inch chase nipple allows easy mounting to a junction box
- Zero downtime Over-the-Air (OTA) firmware updates

0-10V Output

Specifications	Value	Remarks
Number of channels	2	
Voltage range	0-10VDC	Tolerance: $\pm 0.2V$
Current	100mA	Max Source current per channel
Dimming range	0-100%	1000 steps resolution
Dimming curve	linear (default) / logarithmic	

Sensor Input

Specifications	Value
Voltage range	0-10VDC analog input
Input current	2mA

Auxiliary Output

Specifications	Value
Voltage	12VDC
Current	100mA

Bluetooth

Specifications	Value	Remarks
Frequency range	2402 - 2480MHz	
Max output power	8dBm	Conductive
Receiver sensitivity	-95dBm	
Connection distance (device to device)	45m(147.6 ft)	Vary depending on the installation environment

Mechanical

Specifications	Value	Remarks
Dimensions	4.33 x 3.74 x 1.18in (110 X 95.1 X 30mm)	L X W X H
Weight	160g(5.64oz)	
Case material	Polycarbonate	Blue
Flammability rating	UL 94 5VA	

Environmental

Specifications	Value
Operating temperature	-20 to 50°C(-4 to 122°F)
Case temperature	70°C(158°F)
Relative humidity	85%

Product Dimensions

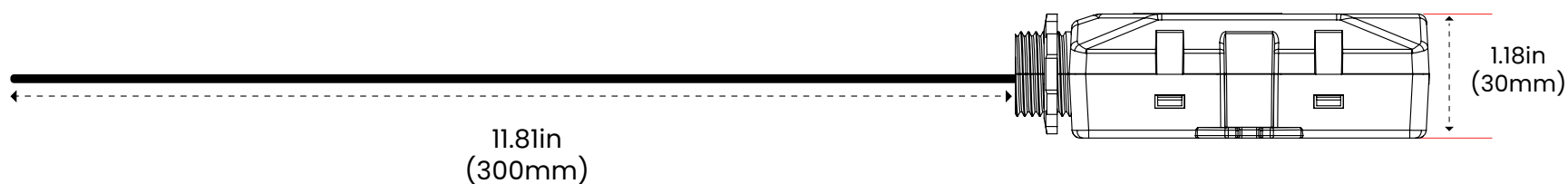
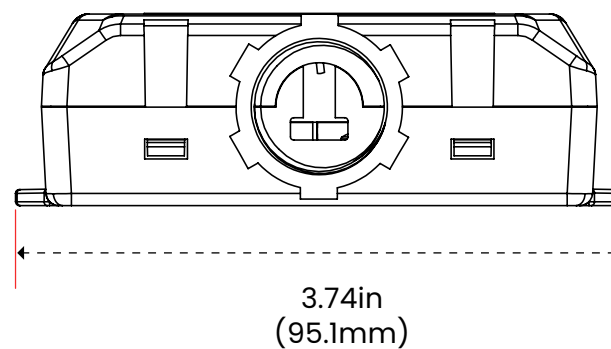
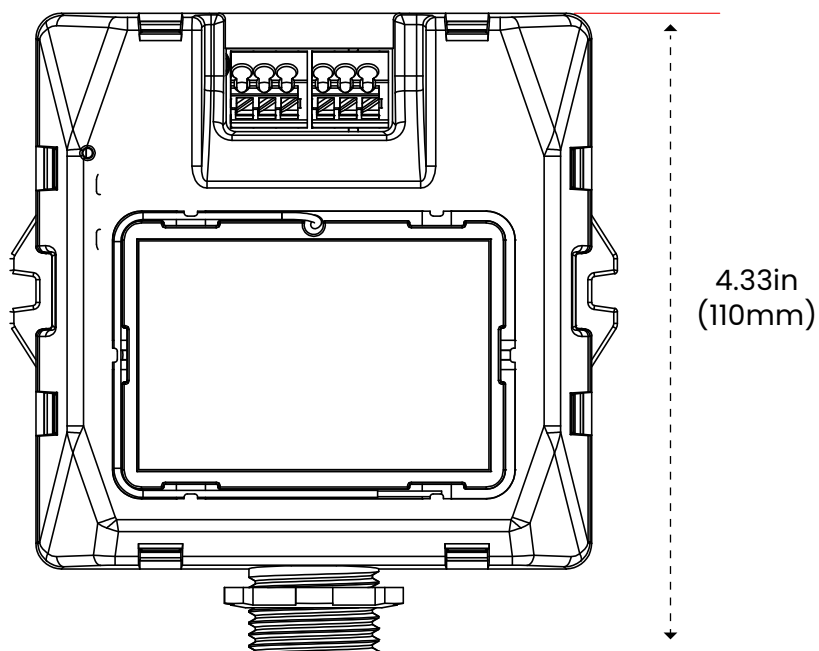

Wire Description

Class-1 Outputs

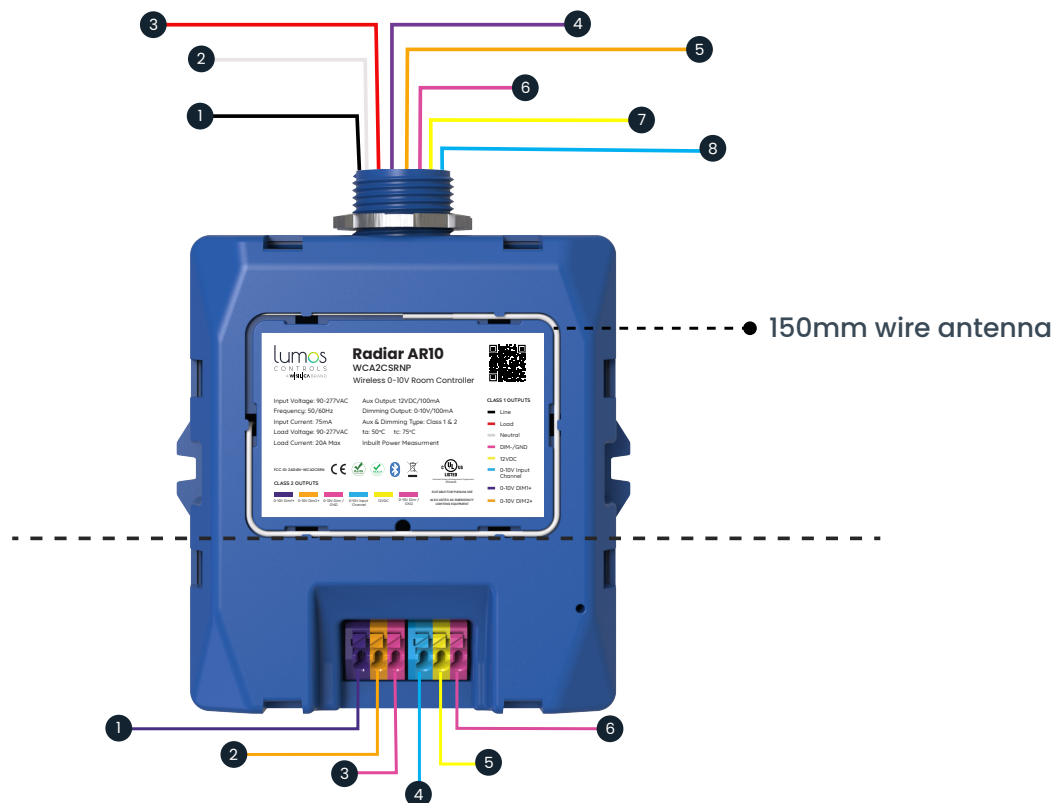

Class-1 outputs

Sl.No	Name	Color	Gauge	Rating	Description
1	Line	Black	12AWG (4.0mm ²)	600V	90-277VAC
2	Common neutral	White	18AWG (0.75mm ²)	600V	90-277VAC
3	Load	Red	12AWG (4.0mm ²)	600V	90-277VAC
4	0-10V DIM1+	Purple	20AWG (0.5mm ²)	600V	0-10VDC/ 100mA
5	0-10V DIM2+	Orange	20AWG (0.5mm ²)	600V	0-10VDC/ 100mA
6	0-10V DIM- /GND	Pink	20AWG (0.5mm ²)	600V	0-10VDC/GND
7	12VDC	Yellow	20AWG (0.5mm ²)	600V	12VDC/100mA
8	0-10VDC sensor input	Blue	20AWG (0.5mm ²)	600V	0-10VDC/2mA

Class-2 outputs

Sl.No	Name	Connector color	Description
1	0-10V DIM1+	Purple	0-10VDC/100mA
2	0-10V DIM2+	Orange	0-10VDC/100mA
3	0-10V DIM- /GND	Pink	0-10VDC/GND
4	0-10VDC sensor input	Blue	0-10VDC/2mA
5	12VDC	Yellow	12VDC/100mA
6	0-10V DIM- /GND	Pink	0-10VDC/GND

Antenna Information

150mm wire antenna



Antenna Properties

Frequency range	2.4GHz-2.5GHz
Impedance	50Ω Nominal
VSWR	1.92:1 Max
Return loss	-10dB Max
Gain(peak)	1.5dBi
Cable loss	0.3dBi Max
Polarization	Linear vertical

Wiring Types

Class-1 wiring

- In Class-1 wiring, the 0-10V low voltage control wires run along with the line voltage wires in a same conduit.
- Class 1 installations require wire with insulation that is rated for the voltage carried (most wiring has 600V rated insulation) and must be installed in conduit or a protective cable assembly.

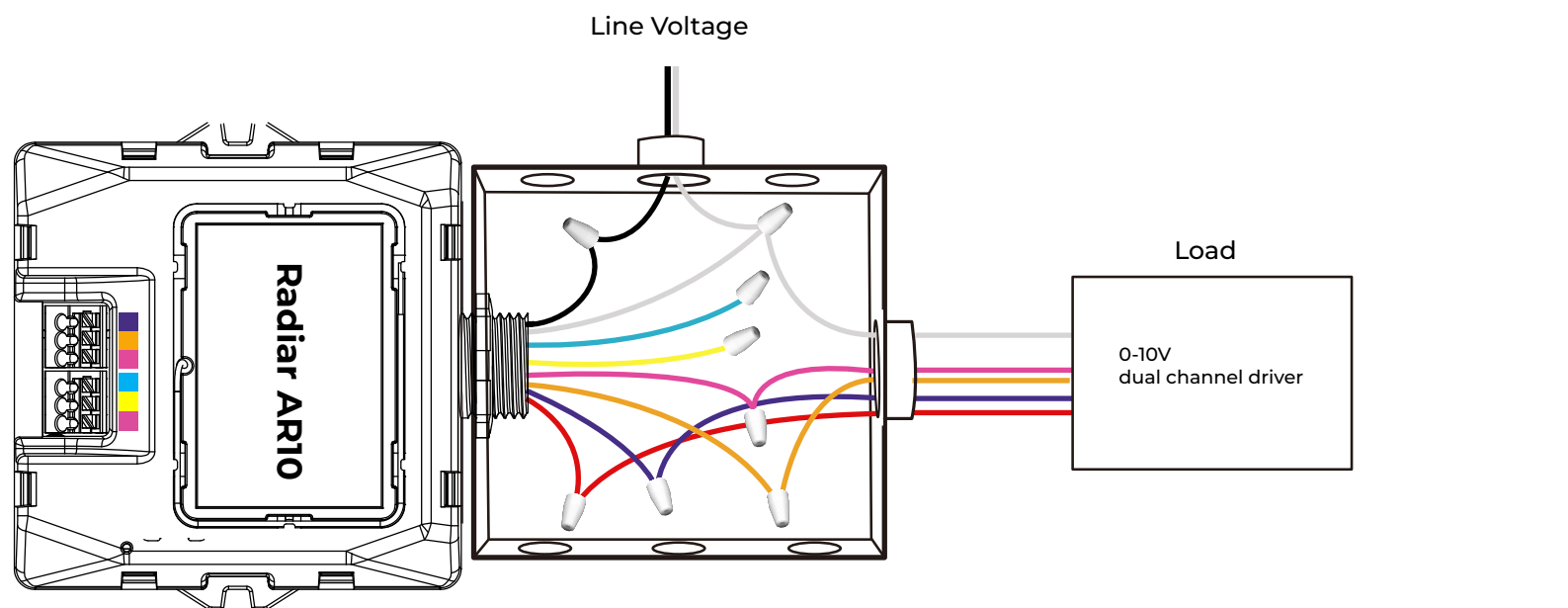

Line (Black)

Neutral (White)

Load (Red)

12VDC (Yellow)

DIM- (Pink)

0-10V DIM2+ (Orange)

0-10V DIM1+ (Purple)

0-10V Sensor input (Blue)

Class-2 wiring

- In Class-2 wiring, the 0-10V low voltage wires run separately in another conduit
- These circuits do not have high enough voltage or current to present a hazard to personnel and have less stringent installation requirements in regards to protection of the wiring.
- A Class-2 wiring may be installed free within the wall or ceiling without line voltage rated insulation or protection of conduit or a cable assembly

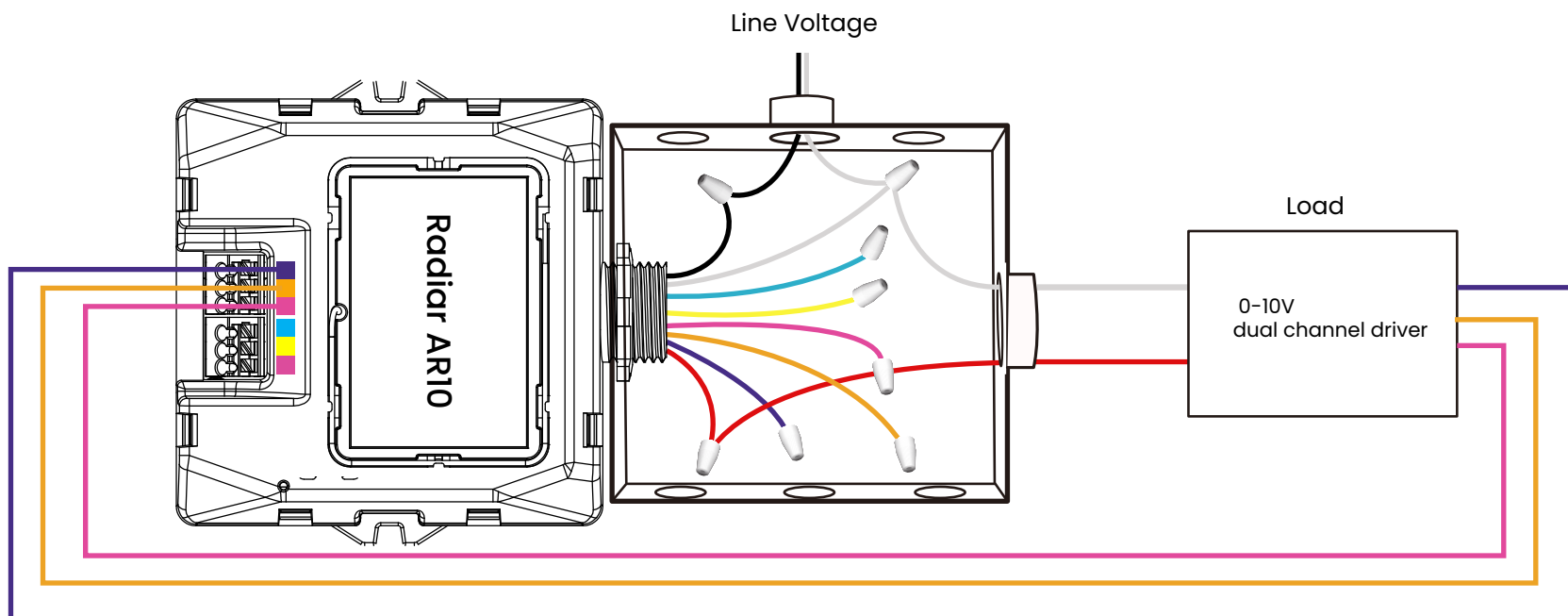

Wiring Diagram

- Configuring Radian AR10 for dimming, tuning and an external sensor control.

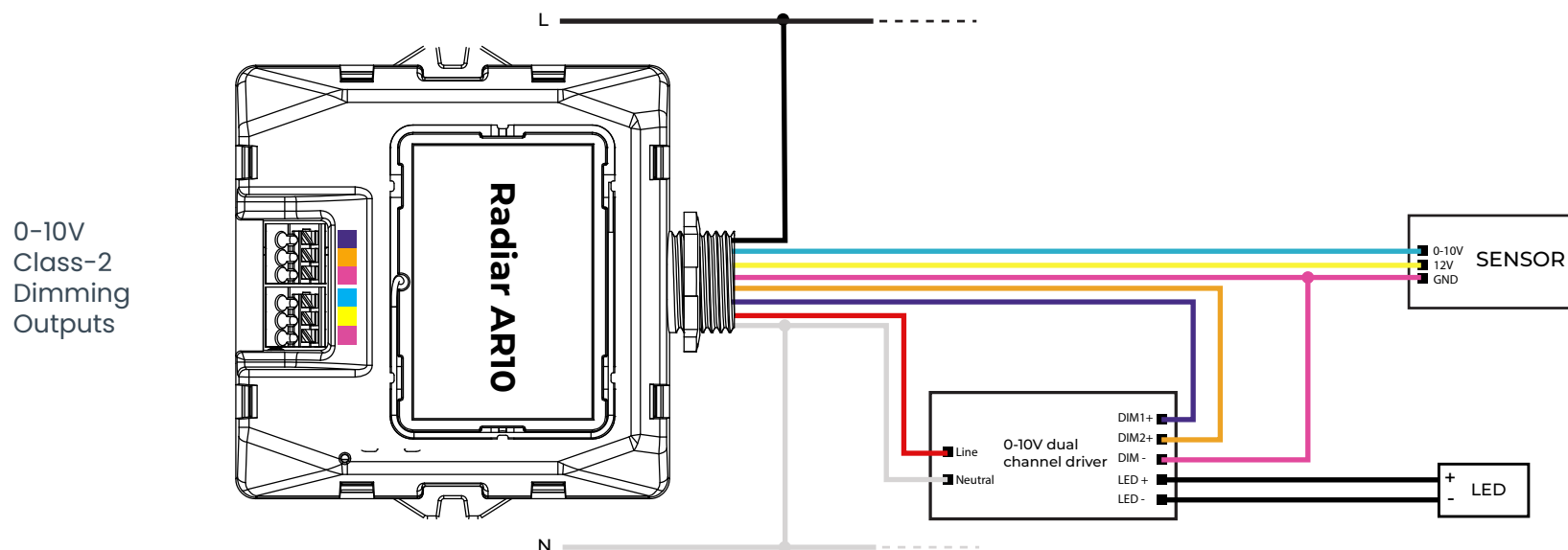

- Configuring Radiar AR10 for plug-load control application

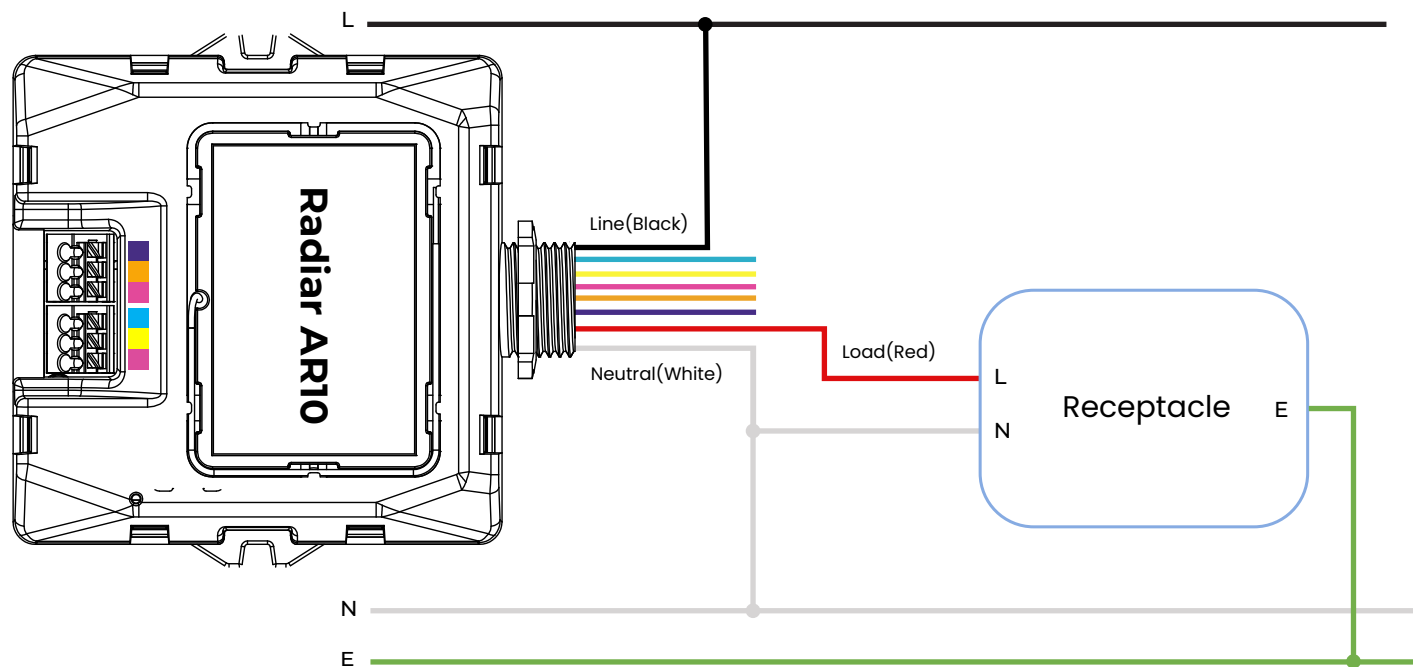

- Configuring Radiar AR10 for **Emergency Lighting**

When the 0-10V input channel of Radiar AR10 does not detect any voltage, it switches to "Emergency Mode"

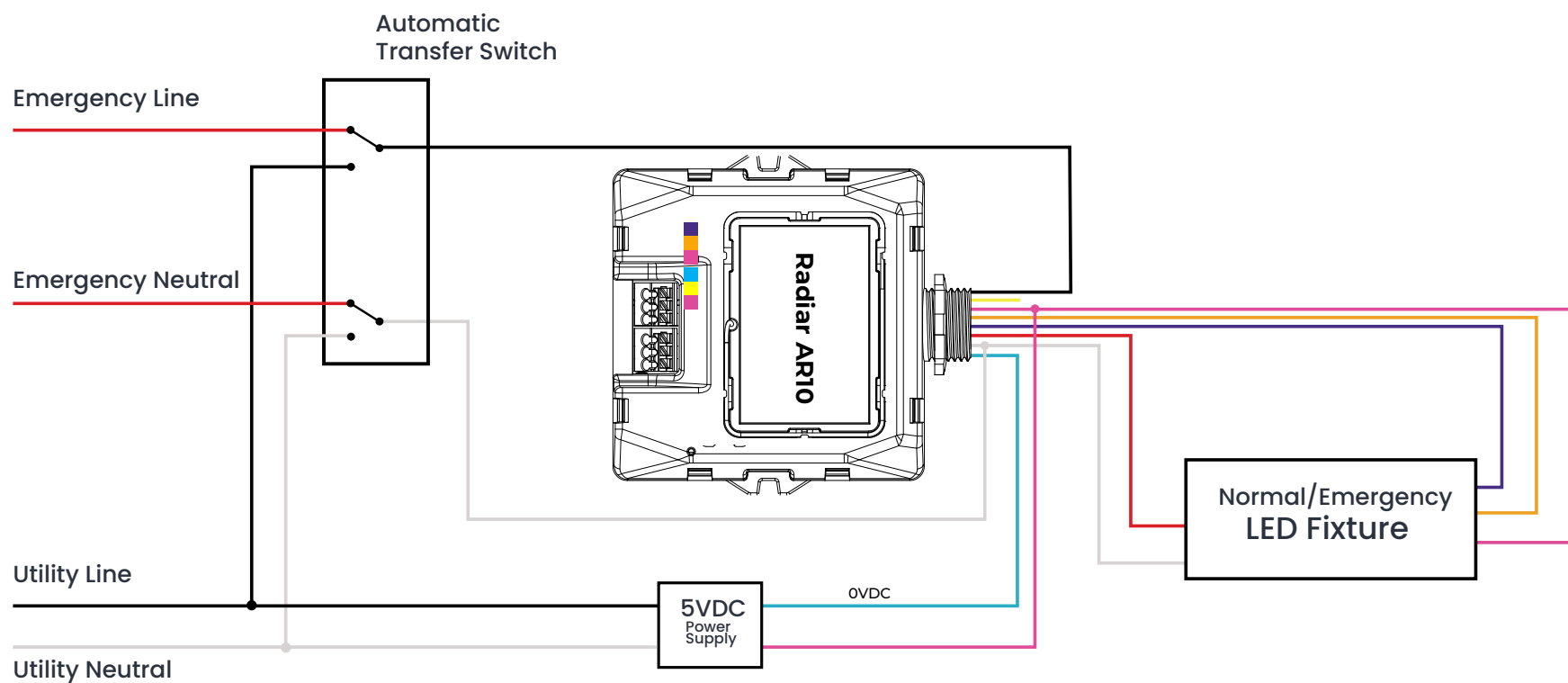

Smart Ecosystem

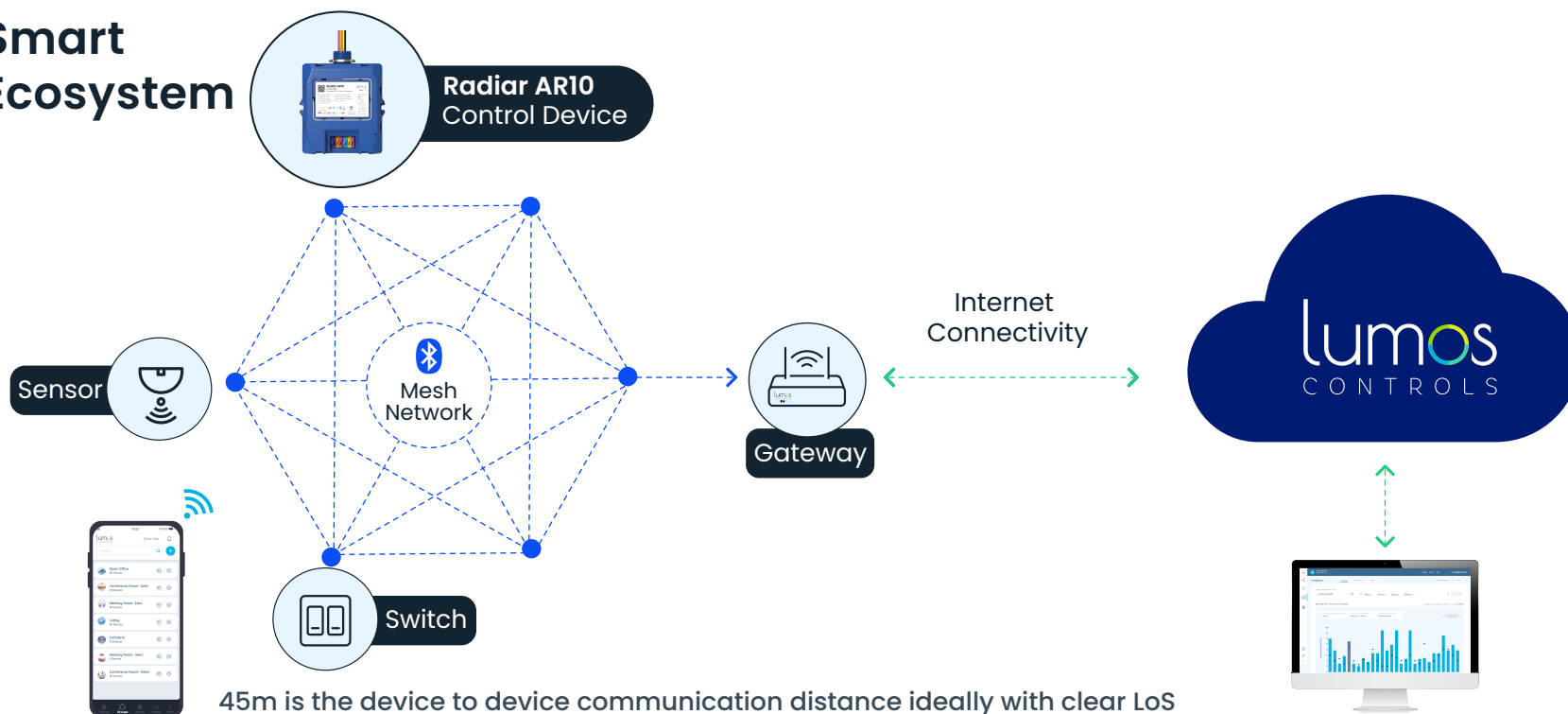

Certifications (In progress)	Details
CE	Article 3, RED 2014/53/EU EMC test standards Safety test standard Radio test standard Health test standard:
cULus	Standards: UL 916, UL 2043, UL 924
FCC	ID: 2AG4N-WCA2CSRNP
RoHS 2.0	RoHS Directive (EU) 2015/863 amending Annex II to Directive 2011/65/EU
REACH	Regulation (EC) No 1907/2006 of REACH
WEEE	Under the WEEE Directive: 2012/19/EU
Bluetooth	Declaration ID: D059551

Items included in the package box

- Radiar AR10
- User manual
- Wirenuts
- Screws
- Wallplugs

Ordering Information

Product Code	Product Name	Product Description	Communication	Voltage Rating	Sensor Input	Output Channel	Aux Power	Relay Control
WCA2CSRNP	Radiar AR10	Wireless 0-10V dual channel dimming AC powered room controller with power measurement	BLE5.2	90-277VAC	0-10VDC	0-10V 2 Channels	12VDC	20A Max

Application

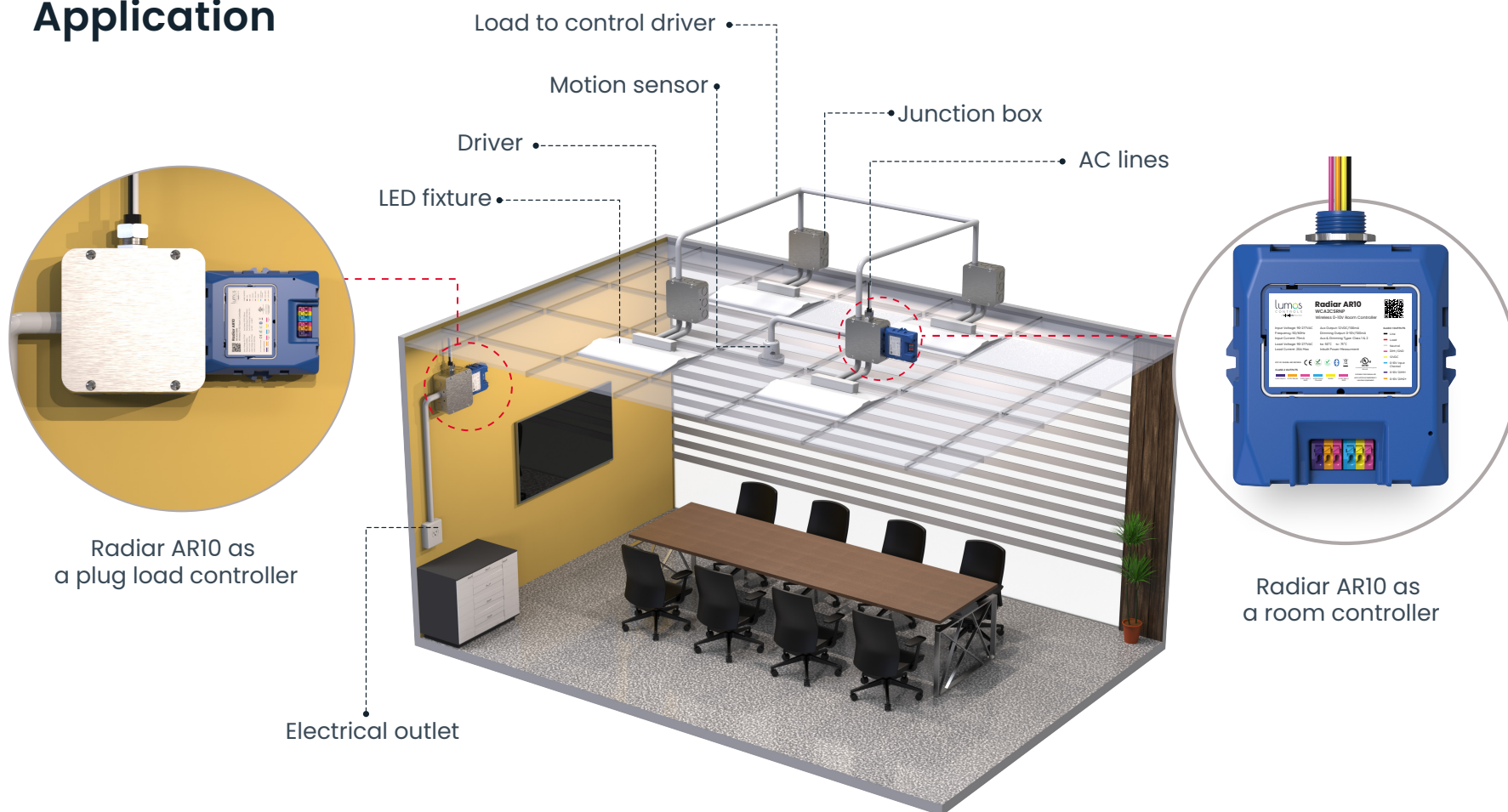

The Bluetooth® word mark and logos are registered trademarks owned by Bluetooth SIG, Inc. and any use of such marks by WiSilica Inc. is under license. Other trademarks and trade names are those of their respective owners.



20321 Lake Forest Dr D6,
Lake Forest, CA 92630

www.lumoscontrols.com

+1 949-397-9330